

Read all instructions BEFORE assembly and USE of product.  
KEEP INSTRUCTIONS FOR FUTURE USE.  
Lea todas las instrucciones ANTES de armar y USAR el  
producto. CONSERVE LAS INSTRUCCIONES PARA USO FUTURO.

## Play Zone Play Space with Compact Fold

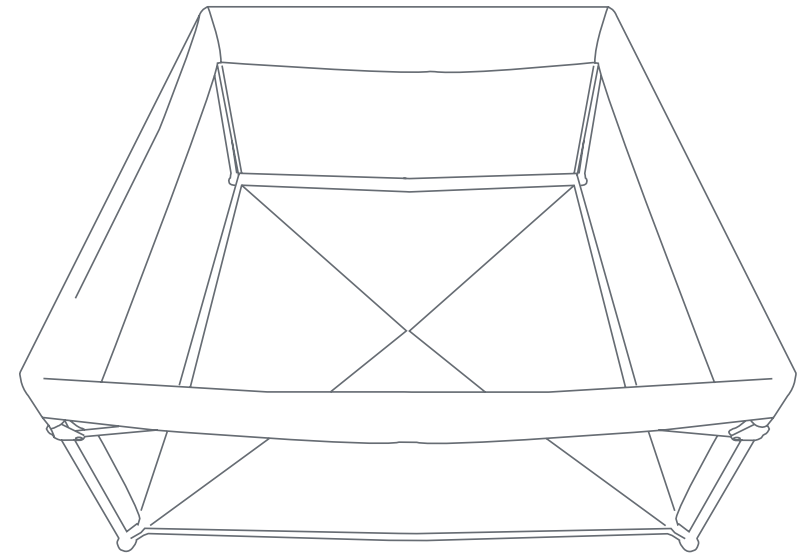

Instruction Manual  
Manual de Instrucciones

**PE02XXXA**

Baby Trend, Inc.  
13048 Valley Blvd.  
Fontana CA 92335

1-800-328-7363  
(8:00 a.m. ~ 4:30 p.m. PST)  
[www.babytrend.com](http://www.babytrend.com)





## WARRANTY

DO NOT RETURN YOUR PRODUCT TO THE STORE. PLEASE CONTACT BABY TREND® FOR REPLACEMENT PARTS, SERVICE AND REPAIR.

The Baby Trend® warranty covers workmanship defects within 1 year of purchase. Any product which has been subjected to misuse, abuse, abnormal use, excessive wear and tear, improper assembly, negligence, environmental exposure, alteration or accident, or has had its serial number altered or removed invalidates all claims against the manufacturer. Any damage to property during installation is the sole responsibility of the end user.

Customer Service Department can be contacted at 1 (800) 328-7363 Monday through Friday between 8:00 a.m. and 4:30 p.m. (PST). Return Authorizations are required prior to returning product(s) to Baby Trend®. Please visit <http://babytrend.com/pages/limited-warranty> for complete warranty details.

## GARANTIA

NO DEVUELVA SU PRODUCTO A LA TIENDA. POR FAVOR CONTACTE A BABY TREND® PARA PIEZAS DE REPUESTO, SERVICIO Y REPARACION.

La garantía de Baby Trend® cubre defectos de fábrica por 1 año después de la compra. Cualquier producto que haya sido sometido a uso inadecuado, abuso, uso anormal, desgaste excesivo, montaje incorrecto, negligencia, exposición ambiental, alteración o accidente, o cuyo número de serie haya sido alterado o removido, anula todos los reclamos contra el fabricante. Cualquier daño a la propiedad durante la instalación es la exclusiva responsabilidad del usuario final.

El Departamento de Servicio al Cliente está disponible llamando al 1 (800) 328-7363, de lunes a viernes de 8:00 a.m. a 4:30 p.m. (PST). Se requiere una Autorización de Devolución antes de poder devolver el o los productos a Baby Trend®. Visite <http://babytrend.com/pages/limited-warranty> para conocer todos los detalles de la garantía.

**Baby Trend, Inc. 13048 Valley Blvd. Fontana CA 92335**

**1-800-328-7363 • (8:00am ~ 4:30pm PST)**

**[www.babytrend.com](http://www.babytrend.com)**

## PLAYPEN WARNINGS:

 **WARNING:** Failure to follow these warnings and the instructions could result in serious injury or death.

- This product is intended for use of a child from 6 to 24 months of age.
- Discontinue use of the product when child is able to climb out or has reached the height of 35 inches (89 cm).
- When child is able to pull to a standing position, remove large toys and other objects that could serve as steps for climbing out.
- The maximum weight capacity is 30 lbs. (13.6 kg)

**STRANGULATION HAZARD** Children have strangled when straps have wrapped around their neck. When not in use, straps must be stored away from children. Always follow the instructions and keep out of reach of children.

**DO NOT USE THIS PLAYPEN IF YOU CANNOT EXACTLY FOLLOW THE INSTRUCTIONS THAT COME WITH IT.**

- Do not place any cord, strap or similar item in or near this playpen that could become wrapped around a child's neck.
- Do not place this playpen near a window or patio door where a child could reach the cord of a blind or curtain and be strangled.
- Check this playpen regularly before using it, and do not use it if any part is loose or missing or if there are any signs of damage. Do not substitute parts. Contact the manufacturer if replacement parts or additional instructions are needed.
- Children can suffocate on soft bedding. Do not place pillows, comforters or an additional floor pad in this playspace.
- Do not leave a child unattended in this playspace.
- Ensure that the sides of this playpen are properly latched or locked in the appropriate position before placing a child in it.

**FAILURE TO FOLLOW THESE WARNINGS AND THE INSTRUCTIONS COULD RESULT IN SERIOUS INJURY**

**OR DEATH. NEVER LEAVE INFANT IN PRODUCT WITH SIDES DOWN.**

Infant may roll into space between pad and loose mesh sides causing suffocation

## SUFFOCATION HAZARD:

- Infants can suffocate:
- In gaps between a mattress too small or too thick and product sides
- On soft bedding .
- **NEVER** add a mattress, pillow, comforter, or padding.
- Prior to use, the product must be fully erected, including side rails.
- Make sure latches are secure.
- Strings can cause strangulation! **NEVER** place items with a string around a child's neck such as hood strings or pacifier cords. **NEVER** suspend strings over playpen or attach strings to toys.
- **NEVER** place product near a window where cords from blinds or drapes can strangle a child.
- **Always** provide the supervision necessary for the continued safety of your child. When used for playing, **NEVER** leave child unattended.
- Child can become entrapped and die when improvised netting or covers are placed on top of a playspace.
- Never add such items to confine child in playspace.
- **NEVER** use this product if there are any loose or missing fasteners, loose joints, broken parts, or torn mesh/fabric. Check before assembly and periodically during use. Contact Baby Trend® Customer Service at 1-800-328-7363 (8:00am ~ 4:30pm PST) for replacement parts, repair or instructions. **NEVER** substitute parts.
- **NEVER** leave child in product with sides lowered. Be sure sides are in raised and locked position whenever child is in product.
- Never use plastic shipping bags or other plastic film as mattress covers not sold and intended for that purpose. They can cause suffocation.
- **NEVER** use a water mattress with this product.
- **NEVER** use this playpen for napping or sleeping. This playpen is designed for playtime **ONLY**.
- **NEVER** place product on counter tops, tables, or any other elevated surface.
- Only place product on a flat surface.
- This product is not intended for commercial use.
- Only one child can use playpen at anytime.

## WARNING

- The playspace, including side rails, must be fully erected prior before use.
- To reduce the risk of SIDS, pediatricians recommend healthy infants be placed on their back to sleep, unless otherwise advised by your physician.
- Always place baby on back to sleep to reduce the risks of **SIDS** and suffocation.

**NEVER** place near pool or fireplace.

**NEVER** use this playpen for napping or sleeping. This playpen is designed for playtime **ONLY**.

Contact Baby Trend Customer Service at 1-800-328-7363 (8:00am ~ 4:30pm PST) for replacement parts, repair or instructions. **NEVER** substitute parts.

### SUFFOCATION HAZARD

Babies have suffocated:

- on pillows, comforters, and extra padding
- in gaps between product sides and a wrong-size mattress or extra padding
- **NEVER** add soft bedding, padding, or an extra mattress.
- **NEVER** leave child unattended. Always keep child in view while in product.
- Children have died or been seriously injured when playpens are not securely installed.

**IMPORTANT!** To ensure safe operation of your product, please follow these instructions carefully. Please keep these instructions for future reference.

**IMPORTANT!** Before assembly and each use, inspect this product for damaged hardware, loose joints, missing parts or sharp edges. **DO NOT** use playpen if any parts are missing, damaged or broken. Discontinue the use of the playpen if it becomes damaged, broken, or disassembled.

**IMPORTANT!** Adult assembly is required.

## ADVERTENCIA

- ¡Las cuerdas pueden causar estrangulamiento! No coloque artículos con cuerdas alrededor del cuello del niño, como por ejemplo cordones de capuchas o sonajeros. No suspanda cuerdas por encima del corral de juegos ni las ate a los juguetes.
- **NO** coloque el corral de juegos cerca de una ventana donde las cuerdas de las persianas o cortinas puedan estrangular al niño.
- **SIEMPRE** asegúrese de que el producto sea seguro: verifique regularmente antes de ingresar al niño que todas las piezas estén montadas de manera correcta y segura.
- Asegúrese de que los laterales estén en la posición trabada siempre que el niño esté dentro del producto.
- El niño se puede enredar y morir cuando se colocan redes o cobertores improvisados por encima del corral de juegos. Nunca agregue dichos artículos para mantener al niño dentro del corral de juegos.

**IMPORTANT!** Para garantizar el funcionamiento seguro de su producto, siga estas instrucciones cuidadosamente. Guarde estas instrucciones para referencia futura.

**¡IMPORTANTE!** Antes del ensamblaje y cada uso, inspeccione este producto en busca de hardware dañado, juntas sueltas, piezas faltantes o bordes afilados. **NO** use el corral de juegos con piezas faltantes, dañadas o rotas. Discontinúe el uso del corral de juegos si se daña, rompe o desarma.

**¡IMPORTANTE!** Se requiere ensamblaje de adultos.

## TO ASSEMBLE PLAY SPACE



Play Space

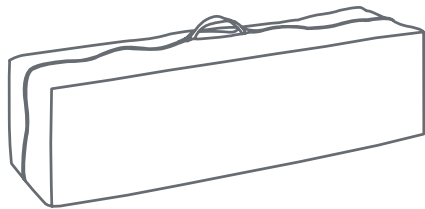

Storage Bag  
Bolsa de viaje y portaobjetos

1

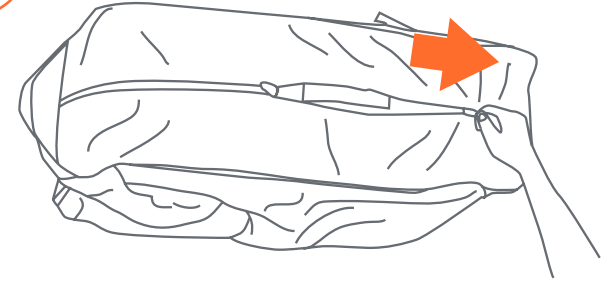

2



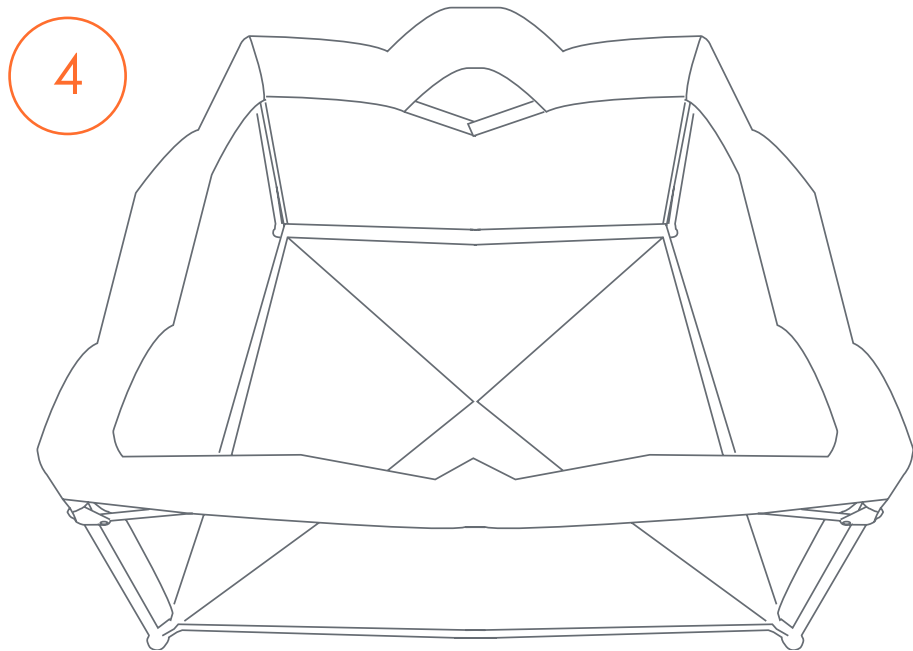
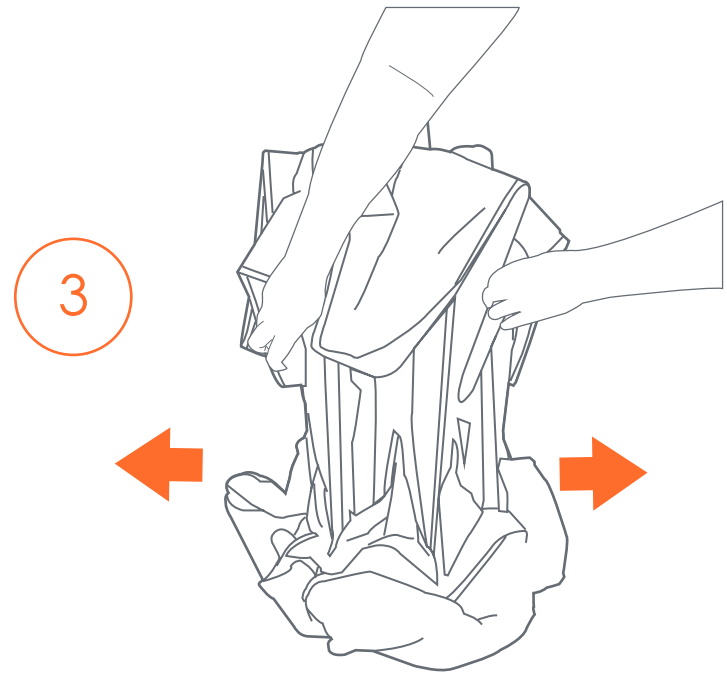

5

\*2 Locks\*

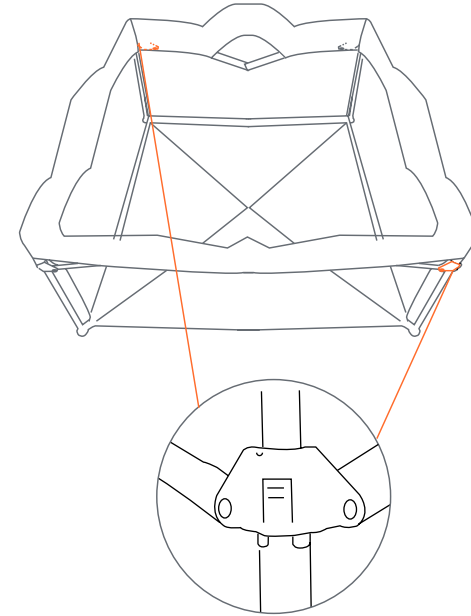

6

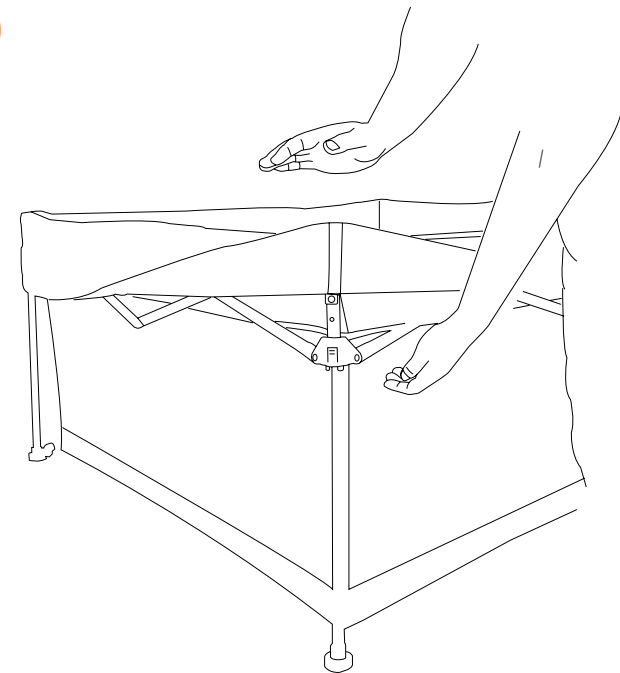

7

One hand pushed down.  
The other pulls up.

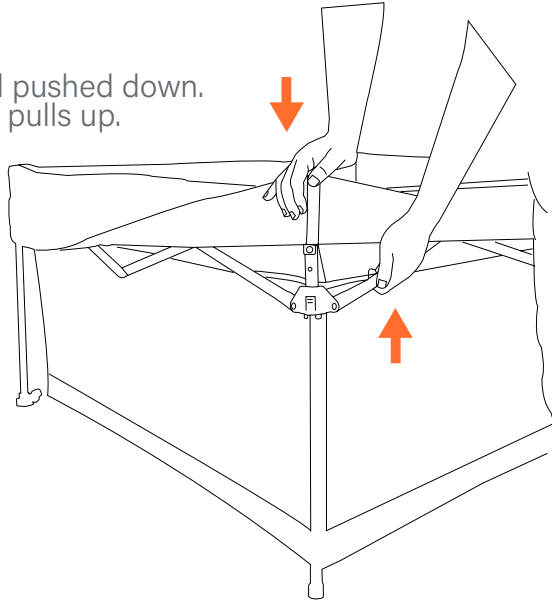

8

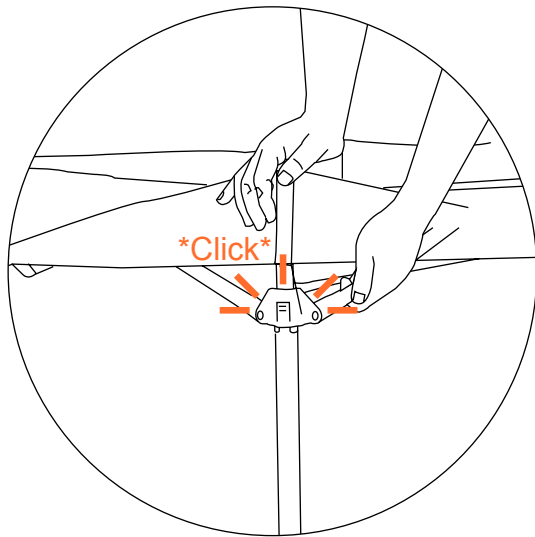

Repeat the same method to lock  
the diagonal side.  
**NOTE:** Make sure both locks are  
secured before each use.

9

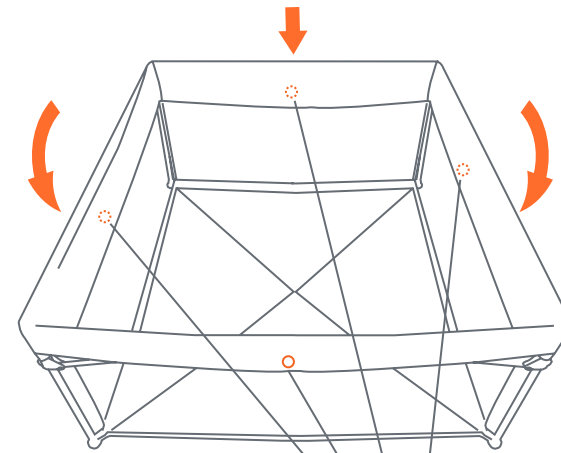

\*Connect snap buttons\*

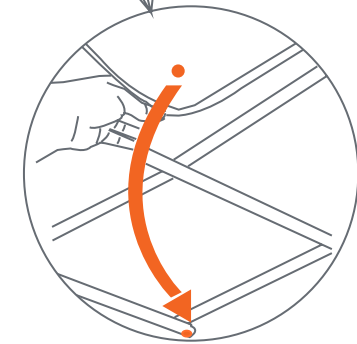

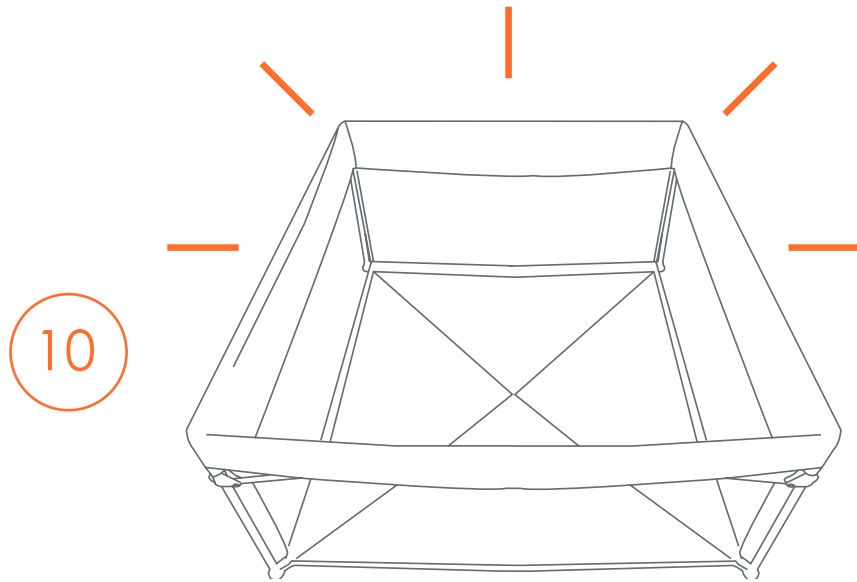

**NOTE:** Be sure playpen is flat before using

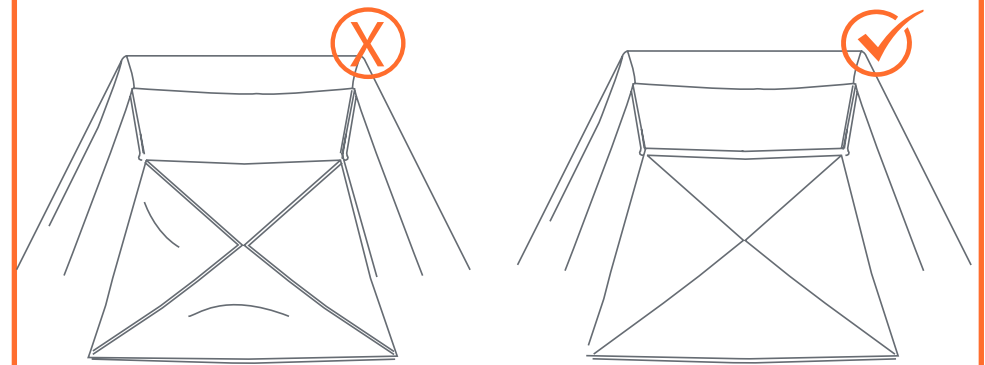

TO FOLD PLAY SPACE

1

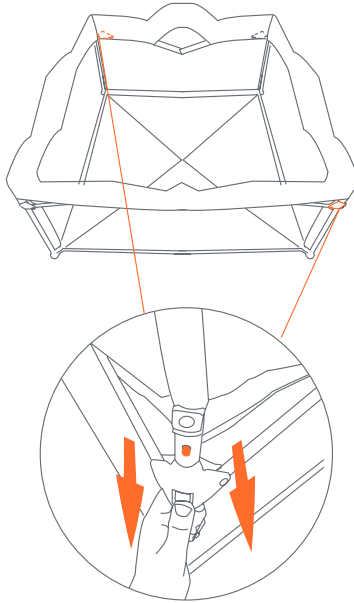

2

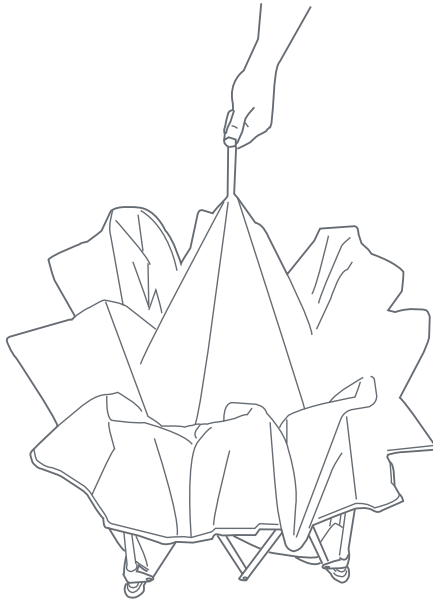

3

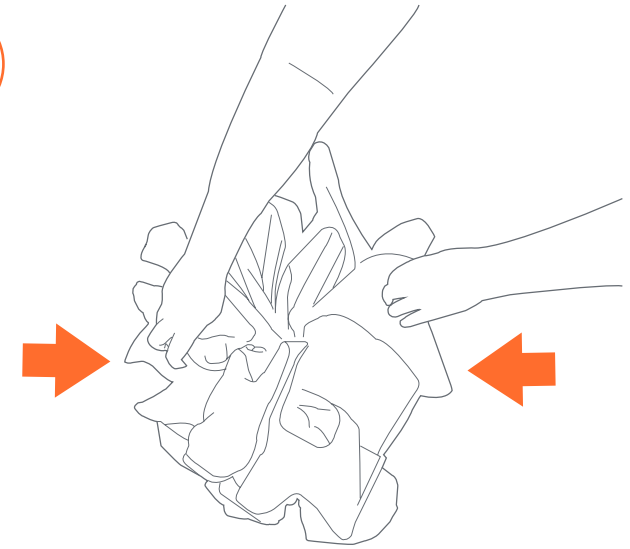

**BABY TREND® CUSTOMER SERVICE**

The Customer Service Department can be contacted at 1 (800) 328-7363 Monday through Friday between 8:00 a.m. and 4:30 p.m. (PST). Return Authorizations are required prior to returning product(s) to Baby Trend®.

**BABY TREND® SERVICIO AL CLIENTE**

El Departamento de Servicio al Cliente puede ser contactado a 1 (800) 328-7363 Lunes a viernes entre 8:00 a.m. y 4:30 p.m. (PST). Un numero de autorizacion es requerido antes de la devolución de los producto(s) a Baby Trend®.